

# UEIPAC Cubes and RACKs

## Programmable Automation Controllers

- Powerful stand-alone embedded controller
- Flexible, compact and rugged
- Standard Linux or VxWorks Operating System
- Eclipse IDE and EPICS CAS support included
- Optional 8347E processor offers hardware encryption via IPsec
- Web/HTML/HTML5 Web Socket interface support.
- Flexible: Over 70 I/O boards available
- Solid-State Drive and/or SD Card-based storage
- 100Base-T, 100Base-FX (fiber), or Gigabit Ethernet
- Synchronization via IEEE-1588 (coming soon, call for details)
- Ideal for HIL (Hardware In the Loop) applications
- Ideal local controller/RTU in SCADA systems

Now available with a Solid-State Hard Drive!!



The UEIPAC is available on all of UEI's platforms!

### General Description:

The UEIPAC offers an unprecedented combination of flexibility, high performance, low cost and small size. The unit is an ideal solution in a wide variety of measurement and control applications including: Temperature control, Remote/unmanned vehicle control, Hardware in-the-loop (HIL) and more. The UEIPAC is also an ideal solution for a host of embedded DAQ applications as it allows systems to be developed without the cost or the additional space required by an external host computer. The UEIPAC is now supporting the VxWorks and Linux operating systems.

A key advantage of the UEIPAC is its standalone application deployment. In PowerDNA systems, the software application is written for, and runs on a host PC that is connected to one or more UEI chassis via Ethernet. In UEIPAC systems, the Linux/VxWorks application runs directly on the UEI RACK or Cube. There is no need for a separate host PC, though you can certainly connect one in a monitoring or supervisory role. This allows smaller, faster, more reliable and higher performance systems. It also eliminates the cost of a dedicated host PC and guarantees

long term availability of the identical hardware. This is critical when certifying products through CE or FDA, etc.

The heart of every UEIPAC is a 5200 or 8347 PowerPC processor running a standard VxWorks or Linux OS. An 8347E version is available for applications requiring encryption. Flash memory contains the OS Kernel and drivers for each of the I/O boards. The CPU board also provides an SD Card slot, Ethernet interface, Inter-cube trigger/sync interface, RS-232

serial port as well as the power supply inputs and a variety of annunciator LEDs. Optional 8 and 16 GByte solid-state hard are also available on GigE based units. The file system which is contained on the SD card or SSD (GigE only), includes the other components of the operating system such as libraries, utilities, init script and daemons. The GigE Cubes and RACKS provide a USB 2.0 port usable with external hard drives or memory sticks. Synchronization is possible via sync connector or IEEE-1588.

The GigE Cubes and RACKs provide dual Ethernet ports, each of which resides at a unique IP address. These are most commonly used to provide separate primary control and diagnostic ports but can also function as teamed/bonded redundant interfaces.

### Hardware Block Diagram: (UEIPAC 300/600)

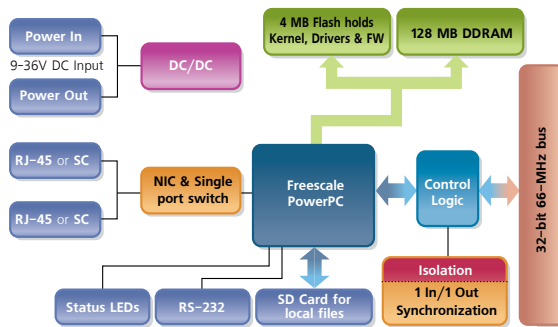

#### Linux Systems

- Uses standard Linux kernel with Xenomai real-time support
- Program in standard C
- Eclipse IDE support
- Develop on Linux PC or Windows PC in the Cygwin environment

#### VxWorks Systems

- Use your existing development license
- Obtain your run-time license from WindRiver
- Our BSP provides everything else you need including examples
- One-time charge for BSP regardless of number of systems deployed

The UEIPAC is supported by all UEI DNA/DNR/DNF series chassis and uses the same I/O boards. There are currently over 70 different I/O boards available including analog input (with up to 24 bit resolution), analog output, digital I/O, MIL-STD-1553, AFDX, ARINC 429/453/708, Serial and CAN communications, counter/timer, quadrature encoder input and more. With this many different I/O boards available, there is sure to be a configuration perfect for your application.

## Linux Programming

Your application runs as a regular Linux process giving you access to the standard POSIX API provided by the GNU C runtime library (glibc) as well as any other library that can be compiled for Linux (for example: libxml, libaudio file...).

New software provided with the UEIPAC includes an EPICS (Experimental Physics and Industrial Control System) Channel Access Server (CAS). Our new LibSharedData software allows easy connection of the UEIPAC to HTML/HTML5 browsers via Web Sockets or other PCs via TCP/IP Sockets.

Whether your application requires a few I/O channels or a few thousand, the UEIPAC is an ideal solution. The UEIPAC's unique combination of Linux operating system, real-time Xenomai support, I/O flexibility, compact size, mechanical and electrical ruggedness, and ease of use is unparalleled.

## UEIPAC Linux TK Programmer's Toolkit

The programmer's toolkit provides the software tools necessary to create an embedded application targeting Linux on the UEIPAC's PowerPC processor. This includes most popular versions of Linux such as Fedora and Suse. The development environment runs on a Linux PC or in the Cygwin environment on a Windows PC. The UEIPAC is also supported by the popular Eclipse IDE. Applications requiring hard real-time functionality are possible using the Xenomai Linux extension.

The UEIPAC development environment includes:

- GCC to cross-compile an application targeting the UEIPAC PPC module
- GNU toolchain tools such as make
- Standard Linux libraries such as glibc
- UEIPAC library for the various I/O boards/devices

The UEIPAC Linux TK is not included with the UEIPAC and must be purchased as a separate item. *Only one Linux toolkit must be purchased, regardless of the number of UEIPAC systems you will deploy.*

The toolkit uses the same API as our popular PowerDNA Cubes, allowing you to reuse existing programs that were designed to run with a PowerDNA Cube over the network. This allows you to develop your application on your desktop, working directly with a "slaved" PowerDNA Cube. Once you are satisfied with your system, you may port the programs to run directly on the UEIPAC Cube with few modifications.

After the UEIPAC power-up, you have a ready to go Linux operating system with FTP and web servers as well as a command line shell accessible from either the serial port or telnet and SSH over the network. You can configure the UEIPAC I/O module to execute your application after booting-up.

## Eclipse IDE support

The UEIPAC is now supported by the Eclipse IDE. Programmers may now take advantage of the many powerful Eclipse tools to build their UEIPAC applications.

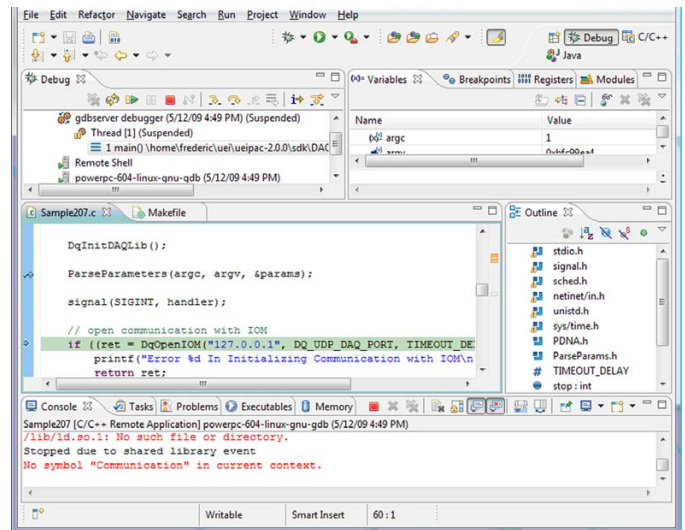

The Eclipse IDE debug screen.

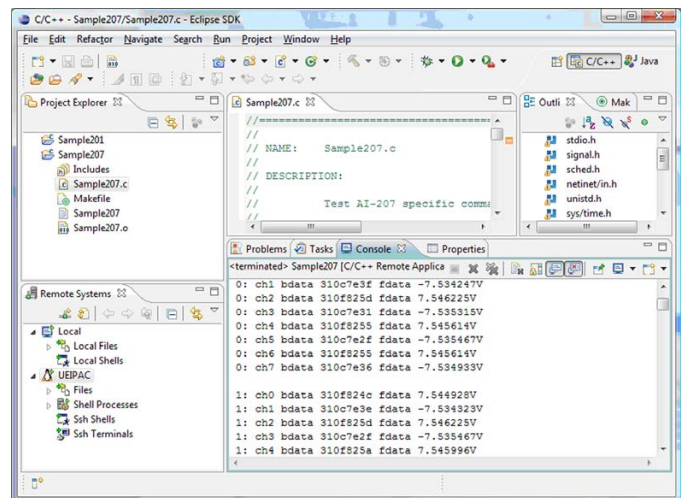

A typical Eclipse IDE run-time screen.

## New Software Support

**EPICS:** (Experimental Physics and Industrial Control System) is popular standard in high-energy physics laboratories. Our new EPICS server provides the source code to set up the UEIPAC as an EPICS CAS (Channel Access Server), allowing you to configure any I/O input or output as a PV (Process Variable).

**Web Browser Interface:** Our new LibSharedData API/library allows easy connection of the UEIPAC to HTML/HTML5 browsers via Web Sockets or other PCs via TCP/IP Sockets. The HTML5 interface is fully compatible with many "mobile" browsers including Safari for iOS and iPhones and iPads and the Android web browser. Of course the standard HTML interface is provided to interface to more general purpose web browsers such as Internet Explorer®.

## VxWorks Programming

You may now take advantage of all the hardware advantages of UEI's popular UEIPAC chassis and continue to develop your applications in VxWorks. This powerful combination provides hard real-time performance, an extremely robust and reliable operating system, allows you to develop your application in a familiar environment and last, but not least, allows you to preserve a great deal of previously written code! To deploy a UEIPAC application running VxWorks you'll need the following.

1. A UEIPAC (any version with GigE Ethernet ports)
2. The "UEIPAC VxW BSP". You only need to purchase the BSP once, regardless of the number of systems you deploy
3. A VxWorks v 6.9.x development system (from Wind River)
4. A VxWorks run-time license for each UEIPAC deployed. (also purchased from Wind River )

Though it's beyond the scope of the datasheet to provide details on how to configure and program the UEIPAC in VxWorks, the following is the table of contents from the current revision of the VxWorks UEIPAC user manual. The steps mentioned should be familiar to existing VxWorks programmers and should help the reader understand the process.

### 1 Configuring and building a VxWorks kernel for UEIPAC

#### 1.1 Installing Software

- 1.1.1 Extract files
- 1.1.2 Build PowerDNA driver

#### 1.2 Building a VxWorks kernel for UEIPAC

- 1.2.1 Create a VxWorks Image Project
- 1.2.2 Kernel Configuration
- 1.2.3 Build Kernel

#### 1.3 Booting VxWorks kernel on UEIPAC

- 1.3.1 Manual boot
- 1.3.2 Store kernel in flash
- 1.3.3 Automatic boot in VxWorks

### 2 Programming with PowerDNA API

- 2.1 Building PowerDNA library
  - 2.1.1 Set-up environment
  - 2.1.2 Install PowerDNA driver source and documentation
  - 2.1.3 Build library using DIAB tools
  - 2.1.4 Build library using GNU tools

#### 2.2 Building an example as a kernel module

- 2.2.1 Creating workbench project
- 2.2.2 Running the example
- 2.2.3 Debugging the example

## UEIPAC: Technical Specifications

Computer Interface	MIL series ruggedized chassis
Primary Ethernet Port	10/100/1000Base-T, 38999 connector
Diagnostic Port	10/100/1000Base-T, 38999 connector
Net Teaming/bonding	supported in both Linux and VxWorks deployments
Config/Serial Port	on LAN/COM 38999 connector
USB Port	USB 2.0 fully supported
Synch Options	Sync input/output port is fully supported
I/O Board Support	
Series supported	All DNR-series boards
Software / Operating System	
Embedded OS	Linux, kernel 3.0.x or VxWorks 6.9.x
Real-time support	Xenomai RTOS support in Linux, VxWorks is a real-time OS
EPICS CAS interface	Yes (Linux version)
SNMP Library	Yes
Processor/system	
CPU	Freescale 8347 or 8347E, 400 MHz, 32-bit
Memory	256 MB
FLASH memory	32 MB standard / 128 MB optional 16 MB / 112 MB available for user apps.
Solid-State Hard Drive	Optional 8 GB or 16 GB drives available
SD card interface	SD cards up to 32 GB
USB drive interface	Standard USB 2.0 port
Physical Dimensions	
4 I/O slots	UEIPAC 400-MIL: 6.2" x 7.1" x 8.7", 11 lbs.
12 I/O slots	UEIPAC 1200-MIL: 17.5" x 8.1" x 7.0" 22 lbs. (Std 3U)
Environmental	
Temp (operating)	-40 °C to 85 °C (power dissipation of actual system may require derated max temp.)
Temp (storage)	-40 °C to 85 °C
Humidity	0 to 95%, non-condensing
Vibration	
(IEC 60068-2-64)	MIL-STD-810G plus the IEC specs below 10–500 Hz, 5g (rms), Broad-band random
(IEC 60068-2-6)	10–500 Hz, 5 g, Sinusoidal
Shock	
(IEC 60068-2-27)	MIL-STD-810G plus the IEC specs below 100 g, 3 ms half sine, 18 shocks at 6 orientations; 30 g, 11 ms half sine, 18 shocks at 6 orientations
Altitude	70,000 feet, maximum
EMI / RFI	Designed to meet MIL-STD-461
Sealing	Default unit sealed to IP 66 or better. Pressure relief valves support continuous altitude changes of 5000 fpm. Units can be configured with bottom weep holes if desired.
Power Requirements	
Voltage	9 - 36 VDC designed to meet MIL-STD-1275
Reliability	
MTBF	>130,000 / 160,000 hrs DNR-12 / DNR-6

# UEIPAC: Technical Specifications

Computer Interface	PPCx series Cubes	PPCx-1G series GigE Cubes	RACKtangle Chassis
Primary Ethernet Port	10/100Base-T, RJ-45 connector	10/100/1000Base-T, RJ-45 connector	10/100/1000Base-T, RJ-45 connector
Diagnostic Port	not applicable	10/100/1000Base-T, RJ-45 connector	10/100/1000Base-T, RJ-45 connector
Other Port functions	Daisy chained single port switch provided	Ports may optionally be bonded/teamed	Ports may optionally be bonded/teamed
Optional Interface	100Base-FX Fiber (single or multi mode)	n/a	n/a
Config/Serial Port	RS-232, 9-pin "D"	RS-232, 9-pin "D"	RS-232, 9-pin "D"
USB Port	not supported	USB 2.0 fully supported	USB 2.0 fully supported
Synchronization Options	1. DNA-SYNC series cables/boards provide system clock or trigger synchronization. 2. DNA-IRIG-650 board provides IRIG and GPS time synchronization 3. PTP client provides software implementation of IEEE-1588	1. DNA-SYNC-1G series cables and boards provide both clock and trigger sync signals. 2. DNA-IRIG-650 board provides IRIG and GPS time synchronization 3. IEEE-1588 synchronization (coming soon please call for details)	1. DNA-SYNC-1G series cables and boards provide both clock and trigger sync signals. 2. DNA-IRIG-650 board provides IRIG and GPS time synchronization 3. IEEE-1588 synchronization (coming soon please call for details)
<b>I/O Board Support</b>			
Series supported	All DNA-series boards	All DNA-series boards	All DNR-series boards
<b>Software / Operating System</b>			
Embedded OS	Linux, kernel 3.0.x or VxWorks 6.9.x	Linux, kernel 3.0.x or VxWorks 6.9.x	Linux, kernel 3.0.x or VxWorks 6.9.x
Real-time support	Xenomai RTOS support in Linux, VxWorks is a real-time OS	Xenomai RTOS support in Linux, VxWorks is a real-time OS	Xenomai RTOS support in Linux, VxWorks is a real-time OS
Dev Language	C/C++, Eclipse IDE support,	C/C++, Eclipse IDE support,	C/C++, Eclipse IDE support
Dev Environments	Linux PC or Cygwin Windows environment	Linux PC or Cygwin Windows environment	Linux PC or Cygwin Windows environment
EPICS CAS interface	Yes	Yes	Yes
SNMP Library	Yes	Yes	Yes
<b>Processor/system</b>			
CPU	Freescale MPC5200, 400 MHz, 32-bit	Freescale 8347 or 8347E, 400 MHz, 32-bit	Freescale 8347 or 8347E, 400 MHz, 32-bit
RAM Memory	128 MB	128 MB standard 256 MB optional	128 MB standard / 256 MB optional
FLASH memory	4 MB (0 MB available for user apps)	32 MB standard / 128 MB optional 16 MB / 112 MB available for user apps.	32 MB standard / 128 MB optional 16 MB / 112 MB available for user apps.
Solid-State hard drive	not available	Optional 8 GB or 16 GB drives available	Optional 8 GB or 16 GB drives available
SD card interface	SD cards up to 32 GB (8 GB included)	SD cards up to 32 GB (8 GB included)	SD cards up to 32 GB (8 GB included)
USB drive interface	n/a	Standard USB 2.0 port	Standard USB 2.0 port
<b>Physical Dimensions</b>			
3 I/O slots	UEIPAC 300: 4.1" x 4.0" x 4.0"	UEIPAC 300-1G: 4.1" x 5.0" x 4.0"	n/a
6 I/O slots	UEIPAC 600: 4.1" x 4.0" x 5.8"	UEIPAC 600-1G: 4.1" x 5.0" x 5.8"	UEIPAC 600R: 5.25" x 6.2" x 10.5"
7 I/O slots	UEIPAC 700: 4.1" x 4.0" x 6.6"		
12 I/O slots	n/a	n/a	UEIPAC 1200R: 5.25" x 6.2" x 17.5" (Std 3U)
<b>Environmental</b>			
Electrical Isolation	350 Vrms	350 Vrms	350 Vrms
Temp (operating)	-40 °C to 85 °C	-40 °C to 70 °C	-40 °C to 70 °C
Temp (storage)	-40 °C to 100 °C	-40 °C to 85 °C	-40 °C to 85 °C
Humidity	0 to 95%, non-condensing	0 to 95%, non-condensing	0 to 95%, non-condensing
<b>Vibration</b>			
(IEC 60068-2-64)	10–500 Hz, 5 g (rms), Broad-band random	10–500 Hz, 3 g (rms), Broad-band random	10–500 Hz, 3 g (rms), Broad-band random
(IEC 60068-2-6)	10–500 Hz, 5 g, Sinusoidal	10–500 Hz, 3 g, Sinusoidal	10–500 Hz, 3 g, Sinusoidal
<b>Shock</b>			
(IEC 60068-2-27)	50 g, 3 ms half sine, 18 shocks at 6 orientations; 30 g, 11 ms half sine, 18 shocks at 6 orientations	100 g, 3 ms half sine, 18 shocks at 6 orientations; 30 g, 11 ms half sine, 18 shocks at 6 orientations	100 g, 3 ms half sine, 18 shocks at 6 orientations; 30 g, 11 ms half sine, 18 shocks at 6 orientations
Altitude	70,000 feet (special version to 120,000')	70,000 feet, maximum	70,000 feet, maximum
<b>Power Requirements</b>			
Voltage	9 - 36 VDC (115/220 VAC adaptor included)	9 - 36 VDC (115/220 VAC adaptor included)	9 - 36 VDC (115/220 VAC adaptor included)
Power	3.5 Watts (not including I/O boards)	7 Watts (not including I/O boards)	10 Watts (not including I/O boards)
<b>Reliability</b>			
MTBF	>300,000 hours	>160,000 hours	>130,000 / 160,000 hrs DNR-12 / DNR-6

## Extended Features:

### Easy to configure and deploy

- Standard Linux operating system (VxWorks Available)
- Eclipse IDE support
- Xenomai RTOS support
- EPICS CAS provided
- Web server
- Web Browser (Web Socket) interface included
- FTP server included
- Over 70 different I/O boards available
- Built-in signal conditioning
- Optional 8 and 16 GB Solid-State hard drives
- Standard SD Card file interface
- Flange kit for mounting to wall/flat surface
- DIN rail and Rack Mount kits
- Standard "Off-the-shelf" products and delivery

### Flexible Connectivity

- 100Base-T or GigE with Cat-5 cable
- RS-232 Interface
- 10/100Base-FX Fiber interface available
- Supports Wi-Fi / GSM / Cell networks

### Rugged and Industrial:

- 100Base-T Cubes operation tested from -40 °C to 85 °C
- RACKS and GigE Cubes operation tested from -40 °C to 70 °C
- 100Base-T Cubes Vibration tested to 5 g
- RACKs and GigE Cubes Vibration tested to 3 g
- Shock tested to 100 g (operating)
- 100Base-T Cubes Operation to 120,000 feet (special version Cube)
- 100Base-T Cubes radiation tested for space applications

### Compact Size and High Channel Density:

- Analog Inputs: up to 175/300 chan. per Cube/RACKtangle
- ICP/IEPE: up to 28/48 channels per Cube/RACKtangle
- Analog Outputs: up to 224/384 chan. per Cube/RACKtangle
- Digital I/O: up to 336/576 DIO per Cube/RACKtangle
- ARINC 429: up to 112/192 channels per Cube/RACKtangle
- Counter/Timer: up to 56/96 counter channels per Cube/RACKtangle
- CAN-bus: up to 28/48 ports per Cube/RACKtangle
- RVDT/LVDT: up to 28/48 channels per Cube/RACKtangle
- RS-232/422/485: up to 56/96 ports per Cube/RACKtangle
- Synchro: up to 28/48 channels per Cube/RACKtangle
- MIL-1553: up to 14/24 redundant ports per Cube/RACKtangle

## Typical Applications:

- Embedded Controller
- Hardware-in-the-loop controller
- Unmanned vehicle controller
- Wind energy and turbine controller
- Smart, Flexible data loggers
- Slaved controller with fail-safe local control and/or shut-down if communication is lost
- HVAC / Environmental controller
- Modern replacement for obsolete VME systems
- Solar Energy system controller
- Machine Health Monitor
- DUT simulator
- In-vehicle test systems
- Avionics simulator
- Single and multiple PID loop controller
- Rugged and remote DAQ

## System Block Diagram:

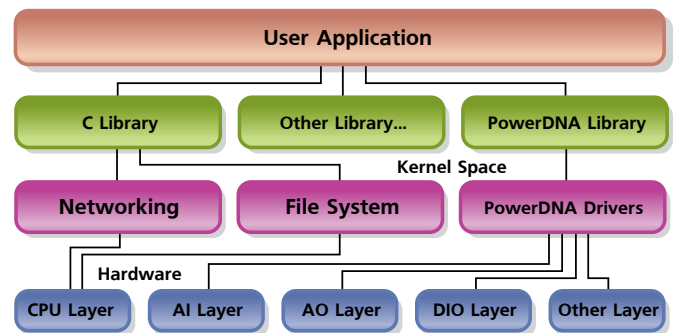

PLEASE SEE ORDERING GUIDE ON THE FOLLOWING PAGE

## Ordering Guide:

### Chassis Configuration

300*	100Base-T Linux-based, Programmable Automation Controller with 3 available I/O slots
600*	100Base-T Linux-based, Programmable Automation Controller with 6 available I/O slots
700*	100Base-T Linux-based, Programmable Automation Controller with 7 available I/O slots
300-1G	Gigabit Ethernet, Programmable Automation Controller with 3 available I/O slots
600-1G	Gigabit Ethernet, Programmable Automation Controller with 6 available I/O slots
600R	Gigabit Ethernet, Programmable Automation Controller, RACKtangle with 6 available I/O slots
400F-AC	1U FlatRACK, rack mountable 4 slot chassis with Gigabit Ethernet and 100-240 VAC AC power
400F-DC	1U FlatRACK, rack mountable 4 slot chassis with Gigabit Ethernet and 9-36 VDC power
400-MIL	Military style, 4 slot Cube with GigE Ethernet ports and 38999 connectivity
1200R	Gigabit Ethernet, Programmable Automation Controller, RACKtangle with 12 available I/O slots
1200-MIL	Military style, 12 slot RACKtangle with GigE Ethernet ports and 38999 connectivity

\* there are no options available on the UEIPAC 300, 600 and 700

UEIPAC

### CPU Configuration

- 00 - standard UEIPAC
- 01 - reserved
- 02 - Updated CPU board supports:
  - IEEE-1588 (when available)
  - solid-state hard drives
  - 256 MB of RAM
- 03 - Updated CPU board adds:
  - IEEE-1588 (when available)
  - solid-state hard drives
  - 8347E encryption ready CPU (IPsec support pending)
  - 128 MB of Flash
  - 256 MB of RAM

### Solid State Hard Drive

- 00 - No SS Drive
- 08 - includes 8 GByte SS Drive
- 16 - includes 16 GByte SS Drive
- 64 - includes 64 GByte SS Drive (special order)

### Software Deployment options

- 00 - Standard UEIPAC deployment
- SM - Simulink (UEISIM) deployment option
- MB - Modbus (UEIModbus) deployment option
- OP - OPC-UA (UEIOPC-UA) deployment option
- PN - Profinet (UEI PNET) deployment option

### SD Card

- 00 - No SD card
- 08 - 8 GByte SD card
- 32 - 32 GByte SD card

For example a 3-slot GigE Cube with 8347E encryption, an 8 GB SS Drive, no SD card in standard PAC mode would be:

UEIPAC 300-1G - 03 - 08 - 00 - 00

All chassis include: Universal AC power supply, Serial and Ethernet cables and Linux OS installed.

### Software including SDK and Board Support Packages

Part Number	Description
UEIPAC VxW BSP (Software Only)	VxWorks Board Support Package (BSP) allows you to program your UEIPAC applications in VxWorks
UEIPAC-Linux TK (Software Only)	UEIPAC Linux Programmer's Toolkit. Only one toolkit is required, regardless of the number of UEIPACs deployed
UEIPAC UPG (Software Only)	Upgrade any PowerPC PowerDNA Cube or RACKtangle to the UEIPAC series