

DNA-STP-SYNC-1G

PowerDNA Sync Interface Interconnection Panel

- Simple connection of external trigger to Cube/RACKtangle chassis
- Buffers internal or external Sync signal to up to 6 slaved chassis
- Allows a master Cube/RACKtangle to channel its trigger pulse through the board's buffers so its timing matches that of the slaves
- Provides BNC and screw terminal connection to sync signals
- Drives triggers up to 50 feet
- Clock sync up to 1000 feet
- Easy DIN rail mounting
- Daisy-chain to additional boards with standard BNC cable or DNA-CBL-SYNC-RJ

10-Year
Availability
Guarantee

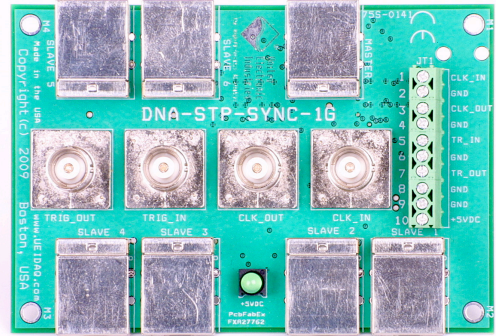

General Description:

The DNA-STP-SYNC board provides a simple method to connect and synchronize multiple Cube and RACKtangle I/O chassis. A single master Cube/RACKtangle or an external Sync signal serves as master for up to 6 additional chassis. Larger systems are possible by daisy chaining boards with a standard BNC cable. All connectors for standard UEI Sync cables and all inputs and outputs are provided on screw terminals and BNC connections. This simplifies synchronizing a system to external devices.

The buffered output of the master cube is connected back into the master Cube or RACKtangle's Sync In. This signal can then be used by the master chassis to as the sync source for the application. This configuration ensures that all sync signals have gone through an identical buffer and that no buffer induced timing skew is introduced.

Technical Specifications:

Sync input connections	3 available, Screw-Terminal, BNC or from a Master Cube via the standard DNA-CBL-SYNC-RJ cable
Slave Cube outputs	5/6 (DNA-CBL-SYNC-RJ cable compatible)
Buffering	All outputs fully buffered
Intercube distance	50 feet max for trigger/1000ft for clock sync
Size / Weight	4.25" by 4.0" / less than 8 oz.
Operating Temp. (tested)	-40°C to +85°C
Operating Humidity	0 - 95%, non-condensing
Power Required	+5 VDC (automatically provided by slaved cubes)
Propagation Delay	5 ns

*Master/daisy chain out/sync in BNC are mutually exclusive, only one can be connected at the time.

Block Diagram:

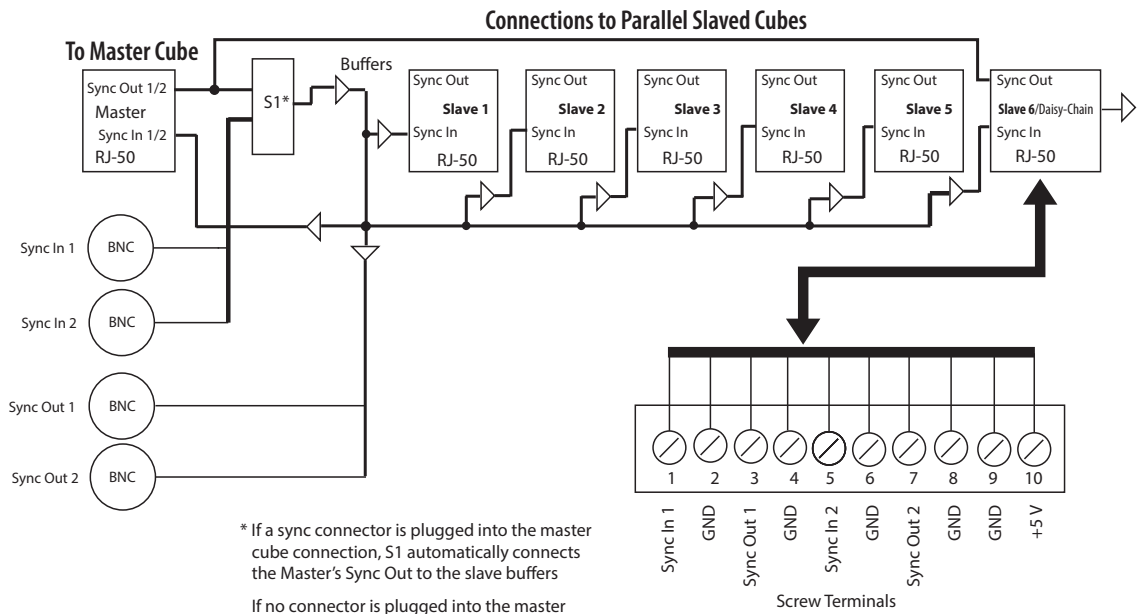

* If a sync connector is plugged into the master cube connection, S1 automatically connects the Master's Sync Out to the slave buffers
If no connector is plugged into the master connector, S1 connects the Sync In BNC signal to the slave buffers

Order Info:

Part Number	Description
DNA-STP-SYNC	SYNC Interconnection Panel (includes DIN Rail mounting kit)
DNA-CBL-SYNC-RJ	PowerDNA/UEI Logger to DNA-STP-SYNC cable

Board Layout:

