

DNR-DIO-432-800

Guardian™ 32-Channel Industrial Digital Output Layer

The Guardian Advantage

- Programmable overcurrent protection (50 mA to 1 A)
- Programmable overcurrent duration limits
- PWM based soft-start/stop reduces inrush current “shock”
- Extremely low <1 μA off leakage current
- 600 mA per channel of continuous output current
- Wide 3.3 V to 36 V operating range
- Output throughput rate of 1 kS/sec

10-Year
Availability
Guarantee



DNR-DIO-432-800 shown

General Description:

The DNR-DIO-432-800 is a 32 channel, digital output layer designed for use in a wide variety of applications. Each channel is configured as a current sink (see diagram on the following page) and switches voltages between 3.3 and 36 VDC. Each channel is rated for continuous operation at 600 mA with an output voltage of less than 550 mV.

The DNR-DIO-432-800 is part of UEI's Guardian series. It not only controls the digital outputs, it provides a unique output monitoring capability. An on-board 24-bit A/D converter monitors each channel's output current. This allows the application to detect and flag short and open circuits as well as other “suspicious” behavior. The monitoring capability is also powerful diagnostic tool allowing a repair technician to quickly and accurately identify blown, or mis-wired channels.

One of the important features of the DNR-DIO-432-800 is the board's extremely low leakage current in the OFF state. With less than 1 microamp of leakage current, the board is an ideal alternative to applications which had previously relied upon electromechanical contacts.

The Guardian advantage includes programmable overcurrent protection. The user may select the current and duration of overload (as short as 10 mS) required before the channel is shut down. Each board provides 350 Vrms isolation between the I/O, the cube and other installed I/O layers. The DNR-DIO-432-800 offers update rates up to 1 kHz and simplifies software writes by transferring all data in a single, 32-bit word.

Each channel offers a pulse-width-modulated (PWM) “soft-start/stop” capability. This allows power to be applied/removed gradually, greatly increasing the reliability of devices like incandescent bulbs where thermal shock reduces life expectancy. The PWM may also be configured to provide a steady state output at less than 100% allowing the unit to function as a programmable “dimmer”.

The DNR-DIO-432-800 is fully supported by the UEIDAQ Framework which provides a simple and complete software interface to all popular programming languages, operating systems and data acquisition and control applications (e.g. LabVIEW, DASyLab, MATLAB).

Technical Specifications:

Number of channels	32 digital outputs
Output configuration	Current sink
Output port configuration	Single 32-bit word
Output Drive	600 mA per channel continuous; 3.5 A peak (100 mS max)
Output ON voltage	< 550 mV @ 600 mA (incl. std 3' cable)
Output ON impedance	< 0.9 Ohm (including std 3' cable)
Output OFF impedance	> 30 Meg Ohm
Output OFF leakage	< 1 μA
Overvoltage protection	±40 VDC (reverse current must be limited to 500 mA to prevent damage)
Overcurrent protection	
Current Limit	50 mA - 2 A
Overload response time	10-5000 ms (user programmable)
Output Monitoring	
Configuration	Multiplexed
Current Accuracy	±1 mA, max (sampled at 10 Hz)
Soft-Start/Stop duration	256 μS to 5 seconds
Steady State PWM output	0 to 100% in 0.4% increments
Output Throughput Rate	1 kHz max
Power up / reboot state	Off
Power dissipation	< 2 W, not including output switches
Isolation	350 Vrms
Operating Temp. Range	Tested -40 to +85 °C
Operating Humidity	95%, non-condensing
Vibration IEC 60068-2-6	5 g, 10-500 Hz, sinusoidal
IEC 60068-2-64	5 g (rms), 10-500 Hz, broad-band random
Shock IEC 60068-2-27	50 g, 3 ms half sine, 18 shocks @ 6 orientations 30 g, 11 ms half sine, 18 shocks @ 6 orientations
MTBF	260,000 hours

Block Diagram:

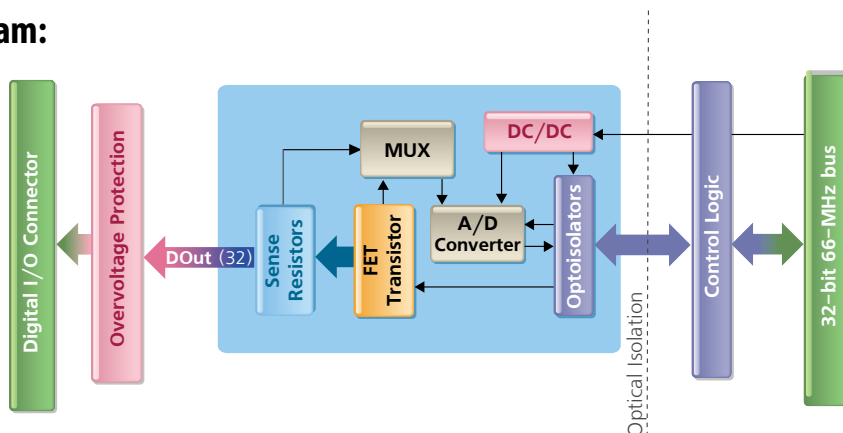

Connection Schemes:

Screw Terminal Panel	Matching Cable	Description
DNA-STP-62	DNA-CBL-62	Connects all I/O signals to easy to use screw terminals

Single Channel Diagram:

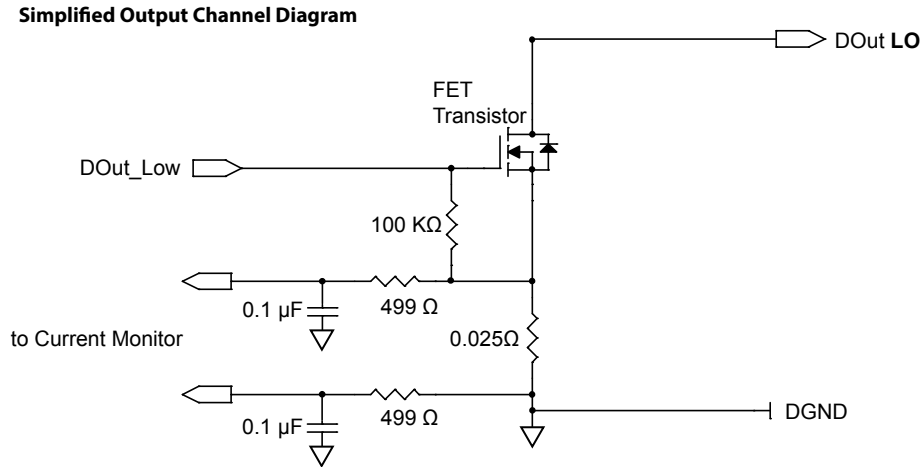

Pinout Diagram:

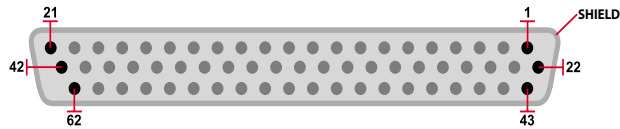

Pin	Signal	Pin	Signal	Pin	Signal
1	Gnd	22	Gnd	43	Gnd
2	Gnd	23	Gnd	44	Gnd
3	DO 1	24	DO 0	45	DO 2
4	DO 4	25	DO 3	46	DO 5
5	Gnd	26	Gnd	47	Gnd
6	DO 7	27	DO 6	48	DO 8
7	DO 10	28	DO 9	49	DO 11
8	Gnd	29	Gnd	50	Gnd
9	DO 13	30	DO 12	51	DO 14
10	DO 16	31	DO 15	52	DO 17
11	Gnd	32	Gnd	53	Gnd
12	DO 19	33	DO 18	54	DO 20
13	DO 22	34	DO 21	55	DO 23
14	Gnd	35	Gnd	56	Gnd
15	DO 25	36	DO 24	57	Rsvd
16	DO 27	37	DO 26	58	Rsvd
17	Gnd	38	Gnd	59	Rsvd
18	DO 29	39	DO 28	60	Rsvd
19	DO 31	40	DO 30	61	Rsvd
20	Gnd	41	Gnd	62	Gnd
21	Gnd	42	Gnd		

Note: For rated performance all ground pins should be connected to the external ground.