

DNx-PC-910/911/912/913

10-Year
Availability
Guarantee

Power Supply Output Boards

- DNR-PC-91x series for RACKtangle chassis
- DNA-PC-91x series for CUBE chassis
- Isolated DC/DC converters
- Overload protection
- Overtemperature shutdown
- Software-controlled On/Off switch
- Readback of input voltage and current

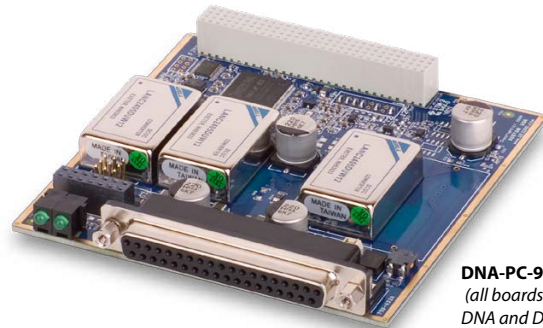

DNA-PC-911 shown
(all boards available in both
DNA and DNR configurations)

General Description:

The DNA-PC-91x and DNR-PC-91x series provide external power to various sensors and signal conditioning when required by your application. The 91x series may also be used to provide power to the various DNx series I/O boards requiring external power. The DNA version is designed for use in UEI's "Cube" chassis while the DNR series is for use in the RACKtangle chassis form factors. The DNx-PC-91x series is fully backward compatible with the DNx-PC-90x series boards.

The DNx-PC-910, 911, 912 and 913 are designed to provide output voltages of ±10 VDC, ±15 VDC, +24 VDC and ±45 VDC respectively. Input power for the boards is provided by the internal Cube or RACKtangle by default, but an external power supply* may be used to power the units. The units are designed to automatically detect the presence of an external supply and use power from it when available.

Outputs may be turned on and off under software control (default is On). The boards provide a read-back capability of the input voltage allowing the application to ensure acceptable input voltage levels.

All connections are through a 37-pin D female connector. The pinout of this connector is identical to that of the earlier DNA-PC-90x series with the exception that pins designated as "NC" on the 90x series are now used as the connections to external power when used.

The DNx-PC-91x series includes software drivers supporting all popular operating systems including: Windows, Linux, QNX, VXWorks, RTX, and most other popular Real-Time Operating Systems. Windows users may take advantage of the powerful UEIDAQ Framework which provides a simple and complete software interface to all popular Windows programming language and data acquisition and control applications (e.g. LabVIEW, MATLAB).

Technical Specifications: (all version unless otherwise noted)

| | |
|------------------------------|------------------------------------------------------------------------------------|
| Input voltage: | Uses the same 9 - 36V DC as chassis in which it is installed |
| Output voltage: | (call for info on other voltages) |
| DNx-PC-910 | ±10 V DC ±3% |
| DNx-PC-911 | ±15 V DC ±3% |
| DNx-PC-912 | +24 V DC ±3% |
| DNx-PC-913 | ±45 V DC ±3% |
| Output current:* | (derated 1.2% per °C above 40 °C) |
| DNx-PC-910 | 1.5 A |
| DNx-PC-911 | 1.2 A |
| DNx-PC-912 | 1.6 A |
| DNx-PC-913 | 0.4 A |
| Output ripple voltage | <100 mV |
| Output enable/disable | software controlled. Default condition is ON |
| Input Selection* | Power provided by internal bus or external connection. Default source is internal. |
| Input protection | 5 A slow-blow fuse |
| Output protection | Short circuit protected, unlimited duration |
| Short circuit output current | 150 % of I _{max} |
| Output Isolation | 350 Vrms, min |
| Input voltage readback acc. | ±1% |
| Temp measurment acc. | ±2 °C |
| Power supply efficiency | >75% at all currents |
| Power consumption | 0.8W (without load) |
| Operating temp. range | -40°C to +85°C (output current derated 1.2% per °C above 40 °C) |
| Operating humidity | 95%, non-condensing |
| MTBF (Hours) | 150,000 |

* When the total power drawn from all DNx-PC-91x series boards in a single chassis exceeds 40 watts, the use of external power is recommended.

Pinout Diagrams:

DB-37 (female)
37-pin connector:

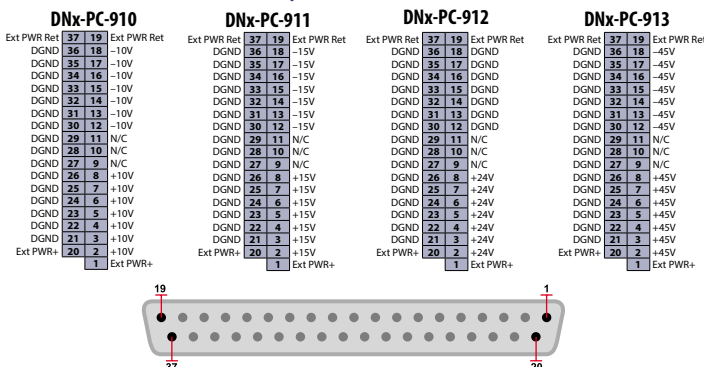

Block Diagram:

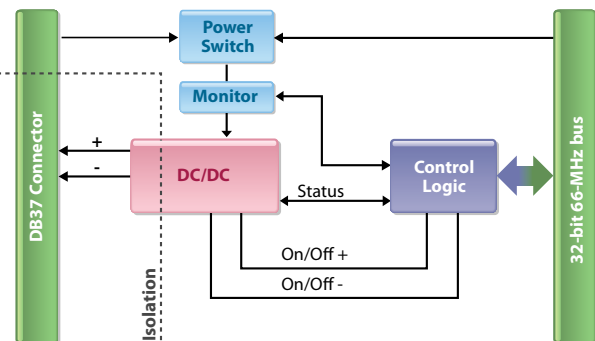

Connections:

| Cable Required | Screw Terminal Panel | Description |
|--------------------|----------------------|------------------------------------------|
| DNA-CBL-37 or -37S | DNA-STP-37 | 37-pin "D" connector to screw terminals. |